

### Features

- ✓ IP65
- ✓ CRI>83
- ✓ No Flicker UGR<19
- ✓ 20cm Can be Cut
- ✓ Easy Installation

### Benefits

- ✓ High Energy Saving
- ✓ High Efficiency
- ✓ Eye Protection
- ✓ Long Life Time
- ✓ Private Mold

### Application

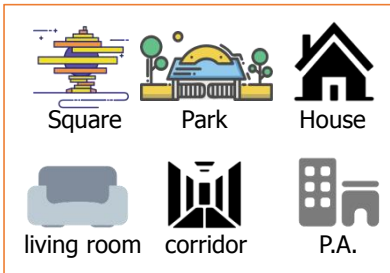

### Certificate

**IEC 60598**

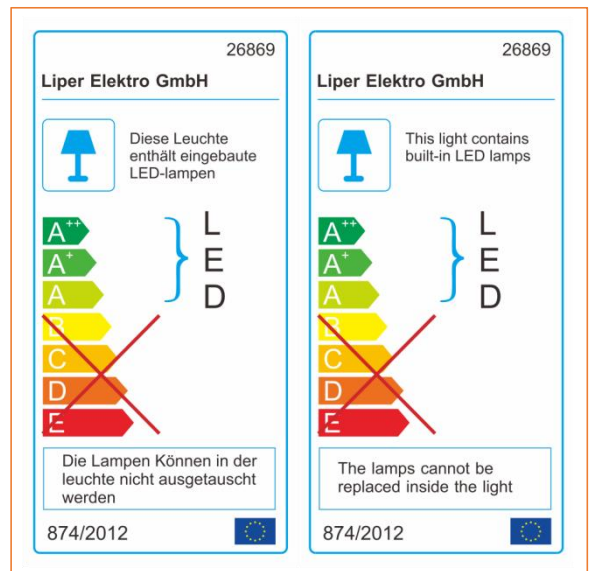

### Specifications

Item Number	Power (W/M)	Power Factor	Lumen (lm)	LED Line	LEDs pcs	CRI	Color Temperature	Life Time (hrs)
LPSTL-7A01	7W/M	>0.9	700±10	1 line	120	>83	3000K	30000
LPSTL-7A01	7W/M	>0.9	700±10	1 line	120	>83	4000K	30000
LPSTL-7A01	7W/M	>0.9	700±10	1 line	120	>83	6500K	30000
LPSTL-12A01	12W/M	>0.9	1200±10	2 lines	120	>83	3000K	30000
LPSTL-12A01	12W/M	>0.9	1200±10	2 lines	120	>83	4000K	30000
LPSTL-12A01	12W/M	>0.9	1200±10	2 lines	120	>83	6500K	30000



### Technical Specifications

On/Off Cycles	100,000
Color Tolerance Adjustment (SDCM)	<6
IP	65
Class	II
LED Driver	Non
LED Beads	120pcs 2835 LEDS
Housing Color	White
Pressure Resistant	3000V

### Temperature

Operating Temperature	-15°C ~ 50 °C
Testing Temperature	-20°C ~ 95 °C

### Packing Data

Item No	PCS/CTN	Gross Weight KG	Net Weight KG	Length CM	Width CM	Height CM
LPSTL-7A01	100m/r, 1 Roll	8.8	7.8	33	33	25
LPSTL-12A01	100m/r, 1 Roll	8.8	7.8	33	33	25

### Dimensional Drawing

Item No	Power	Width (mm)	Cutting Size (mm)
LPSTL-7A01	7W	80	20
LPSTL-12A01	12W	110	20

### Application Scenarios



### Power Supply





carry 50 meters at most

For technical information contact the Technical Assistance Service or visit [liperlighting.com](http://liperlighting.com)

## Installation Instruction

### Accessories for High Voltage strips

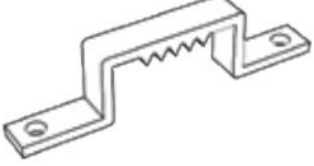
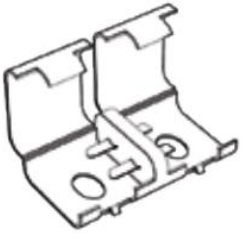
			
Power Connector	End Cup	Mounting Clip	Splice Connector

- A. Cut the strip at the point printed with the mark of scissor
- B. Aim the navigating pin of the power wire to the electric line of the strip and plug it into the strip vertically
- C. Inject glass glue
- D. Seal the tail part of the strip with the end cap
- E. Plug the splice connector vertically to the strip
- F. Inject glass glue

